

DETAIL C

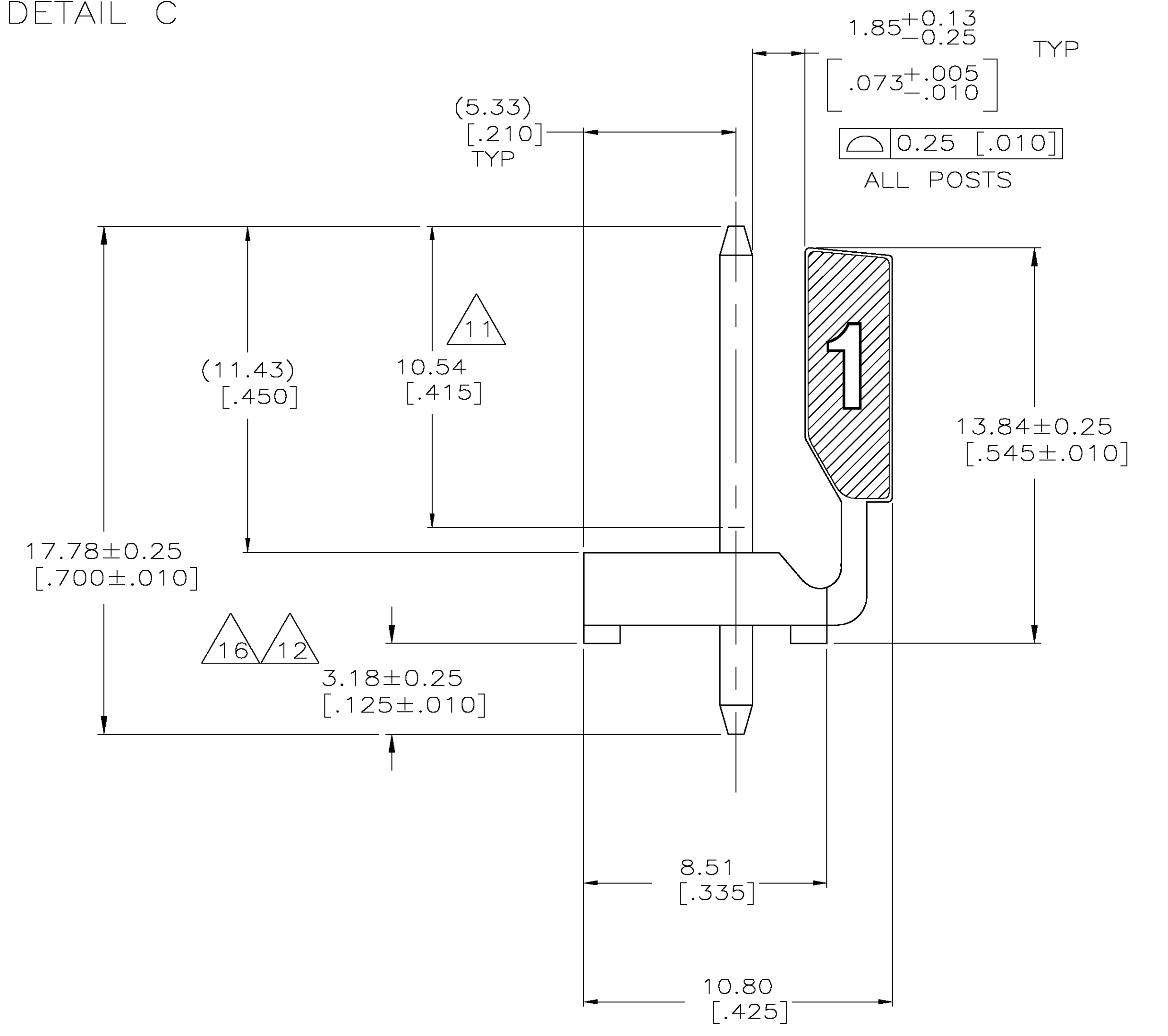

- 1 MATERIAL
HOUSING: THERMOPLASTIC POLYESTER, GLASS FILLED, UL94V-0
POST: COPPER ALLOY
- 2 FINISH
HOUSING: NATURAL
POST: SEE NOTES 11, 12, & 16 FOR PLATING.
- 3 UL MARKING MAY NOT APPEAR ON THE 2 OR 3 POSITION SIZES.
CSA MARKING MAY NOT APPEAR ON THE 2 POSITION SIZE.
- 4 POST SOLDERDETAILS COMPLY WITH TYCO SOLDERABILITY SPECIFICATION 109-11-2.
- 5 POST WITHSTANDS 13.34 NEWTONS (3 LBS) MINIMUM AXIAL FORCE IN EITHER DIRECTION WITHOUT DISLODGING.
- 6 APPLIES AT -A-
- 7 APPLIES WHEN THE HEADER IS STRAIGHT.
- 8 PLASTIC PROJECTIONS PERMITTED IN THIS ZONE.
- 9 COORDINATE DIMENSIONS APPLIES FROM CENTER OF THE ACTUAL FEATURE.
- 10 SOLDER SIDE OF BOARD IS SHOWN.
- 11 PLATING: GOLD PLATE AREA 0.00076 [.000030] MIN., ALL OVER NICKEL UNDERPLATE, 0.00127 [.000050] MINIMUM ALL OVER AND ENTIRE LENGTH OF POST.
- 12 PLATING: BRIGHT TIN-LEAD (93/7) PLATE AREA, 0.00381-0.00889 [.000150-.000350] THICK, ALL OVER, 3.18 [.125] MINIMUM.
- 13. DIMENSIONS IN BRACKETS ARE IN INCHES.
- 14 ALL POSITION SIZES HAVE THE BACK WALL NOTCHED ON BOTH ENDS AS SHOWN. THE 2 THRU 5 POSITION SIZES HAVE SOLID BACK WALLS. POSITION SIZES 6 AND ABOVE HAVE AN INTERRUPTED BACK WALLS AT VARIOUS LOCATIONS (SEE TABLE FOR INTERRUPTION(S) LOCATIONS).
- 15 EDGE OF POLARIZING LOCK WALL TO BE IN LINE WITH CENTERLINE OF ADJACENT POST WITHIN ±0.13 [.005].
- 16 PLATING: MATTE TIN PLATE AREA, 0.00381-0.00889 [.000150-.000350] THICK, ALL OVER, 3.18 [.125] MINIMUM.

4&5	7&8	11&12	14&15	71.20	[2.803]	18	4-644628-8
4&5	7&8	10&11	13&14	67.23	[2.647]	17	4-644628-7
4&5	8&9	12&13		63.27	[2.491]	16	4-644628-6
4&5	8&9	11&12		59.31	[2.335]	15	4-644628-5
4&5	7&8	10&11		55.35	[2.179]	14	4-644628-4
4&5	7&8	10&11		51.38	[2.023]	13	4-644628-3
4&5	8&9			47.42	[1.867]	12	4-644628-2
4&5	7&8			43.46	[1.711]	11	4-644628-1
3&4	7&8			39.50	[1.555]	10	4-644628-0
3&4	6&7			35.53	[1.399]	9	3-644628-9
4&5				31.57	[1.243]	8	3-644628-8
4&5				27.61	[1.087]	7	3-644628-7
3&4				23.65	[.931]	6	3-644628-6
	NONE			19.69	[.775]	5	3-644628-5
	NONE			15.72	[.619]	4	3-644628-4
	NONE			11.76	[.463]	3	3-644628-3
	NONE			7.80	[.307]	2	3-644628-2

4&5	7&8	11&12	14&15	71.20	[2.803]	18	1-644628-8
4&5	7&8	10&11	13&14	67.23	[2.647]	17	1-644628-7
4&5	8&9	12&13		63.27	[2.491]	16	1-644628-6
4&5	8&9	11&12		59.31	[2.335]	15	1-644628-5
4&5	7&8	10&11		55.35	[2.179]	14	1-644628-4
4&5	7&8	10&11		51.38	[2.023]	13	1-644628-3
4&5	8&9			47.42	[1.867]	12	1-644628-2
4&5	7&8			43.46	[1.711]	11	1-644628-1
3&4	7&8			39.50	[1.555]	10	1-644628-0
3&4	6&7			35.53	[1.399]	9	644628-9
4&5				31.57	[1.243]	8	644628-8
4&5				27.61	[1.087]	7	644628-7
3&4				23.65	[.931]	6	644628-6
	NONE			19.69	[.775]	5	644628-5
	NONE			15.72	[.619]	4	644628-4
	NONE			11.76	[.463]	3	644628-3
	NONE			7.80	[.307]	2	644628-2

